

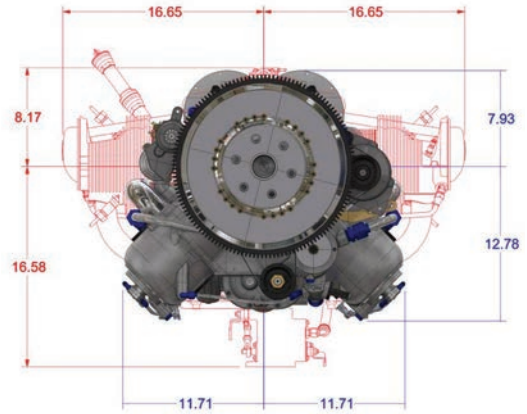

V4 ENGINES

Certified Engines for General Aviation.
Experimental and Certified Aircraft.
Unmanned Aerial Vehicles.

Lightweight 180 hp Heavy Fuel Engines



Profiles for DeltaHawk and Lycoming® 10-360 with matched prop flanges

TECHNICAL DESCRIPTION

Horsepower	180 hp at 2700 rpm
Torque	350 ft/lbs at 2700 rpm
Displacement Bore and Stroke	4 in x 4 in
Stroke and Cycle	2-Stroke Diesel Cycle
Compression Ratio	19.3:1
Configuration	90° V4
Rotation	Clockwise or Counter-Clockwise
Thrust Direction	Pusher or Tractor
Dry Weight	315 lbs / 142 kg
Cooling	Glycol/Water
Lubrication	Oil Pump/Dry Sump
Fuel System	Engine Driven Low Pressure Delivery Pump Mechanical High Pressure Fuel Injection Individual Fuel Injection Pump for Each Cylinder
Combustion Air	Turbocharged and Supercharged with Bypass Valve Intercooled
Prop Flange	SAE 2L Drilled for Hydraulic Props
Electrical	70 Amp, 28 Volt Alternator Standard 28 Volt Lightweight Aviation Starter Standard

TOMORROW'S POWER PLANT IS HERE.

- 180 Horsepower
- 315 Lbs / 142 Kg
- Heavy Fuel Operation (Jet-A)
- Upright, Inverted & Vertical Shaft Models
- Exceptional Fuel Economy
- Simple and Reliable
- Redundant Systems for Flight Reliability
- Thermal Stability through Liquid Cooling
- Patented & Proprietary Technologies
- Member: ASTM Aviation Fuels Committee

THE FREEDOM TO FLY.

deltahawk.com

DeltaHawk DH180A4

Jet Fueled Piston Power for the New Century



- 11.8 GPH @ 180 hp (100%)
- 8.0 GPH @ 135 hp (75%)
- 100% Power to 15,000 feet MSL
- Upright, Inverted and Vertical Shaft Models
- Uses Most Common Jet and Diesel Fuels
- Service-Friendly Externally Mounted Critical Components

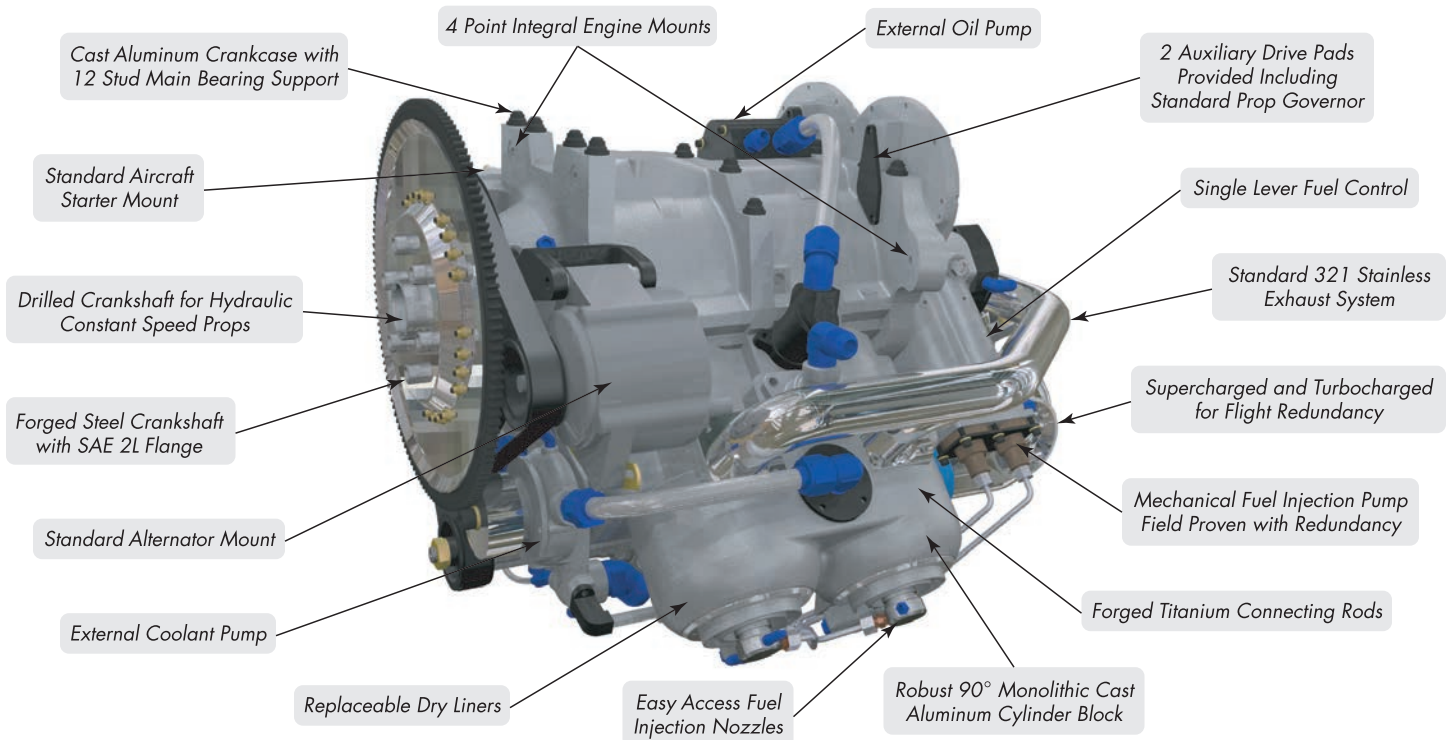

2300 South Street
Racine, WI 53404 USA
www.deltahawk.com
Sales: sales@deltahawk.com
Phone: 1 (262) 583-4500
Fax: 1 (815) 301-8154

© 2017 DeltaHawk Engines

® DeltaHawk is a registered trademark of DeltaHawk Engines, Inc.
Other trademarks appearing in this document are the property of their respective entities.